

Chip Conveyor Enquiry Form:

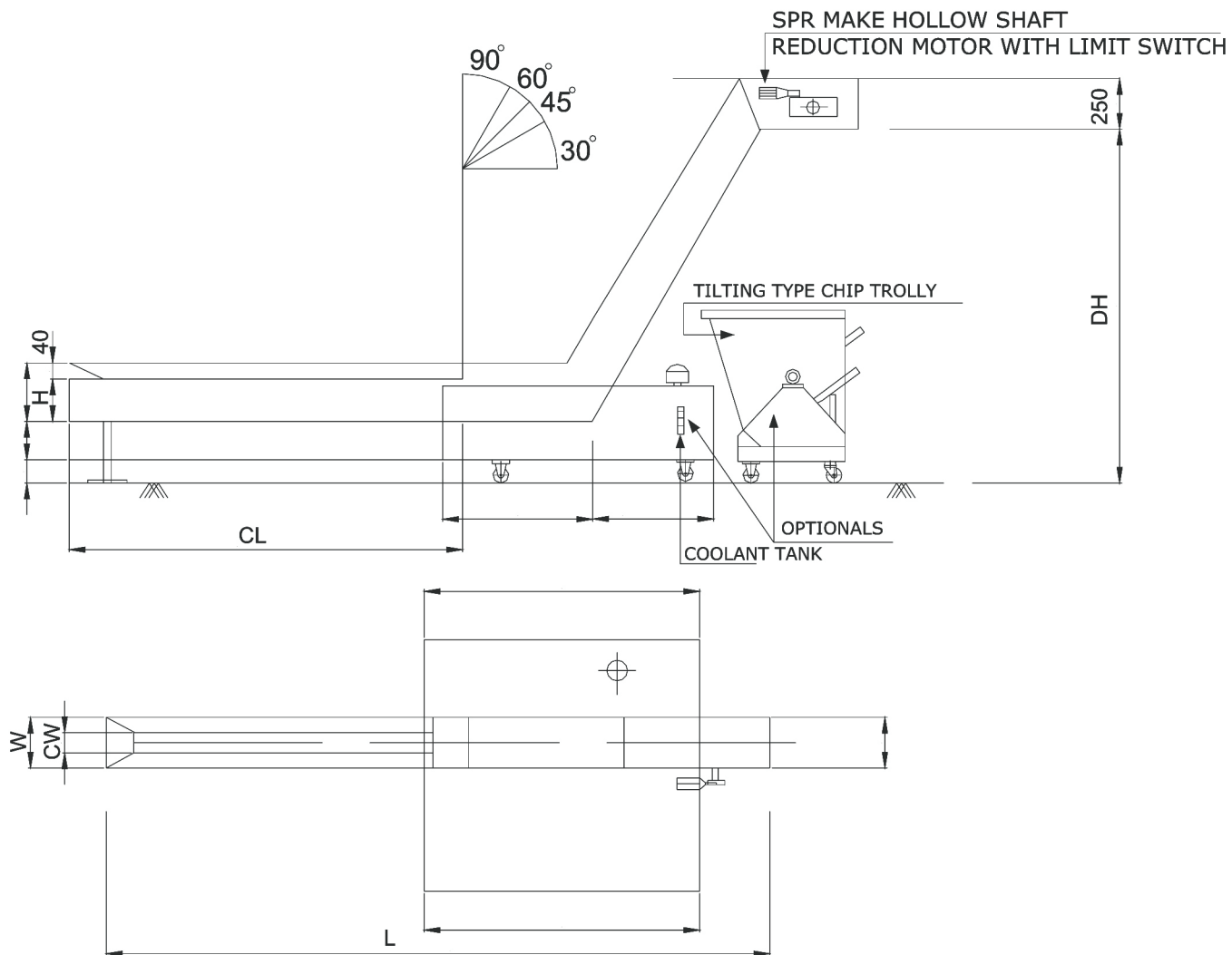

| SPECIFICATION REQUIRED | |
|-------------------------------------|---------------------------------|
| OVERALL LENGTH L= | ANGLE OF INCLINATION = |
| CHARGE LENGTH L= | PITCH OF THE CHAIN=38.1 OR 60.8 |
| DISCHARGE HEIGHT DH= | ELECTRIC MOTOR =1500 RPM |
| WIDTH OF THE CONVEYOR BODY W= | SPEED REDUCER=200:1 |
| HEIGHT OF THE CONVEYOR BODY H= | COOLANT FLOW RATE = |
| CHARGE WORKING WIDTH CW = | CUT OUT POSITION FOR DRAIN PLUG |
| TYPE | SALT CONVEYOR |
| | SCRAPER CONVEYOR |
| | MAGNETIC CONVEYOR |
| TYPE OF CHIPS:- STEEL,ALU,CAST-IRON | |

Your Company :

Customer Enquiry Number :

Contact :

Email :